

# Kitchen Hood

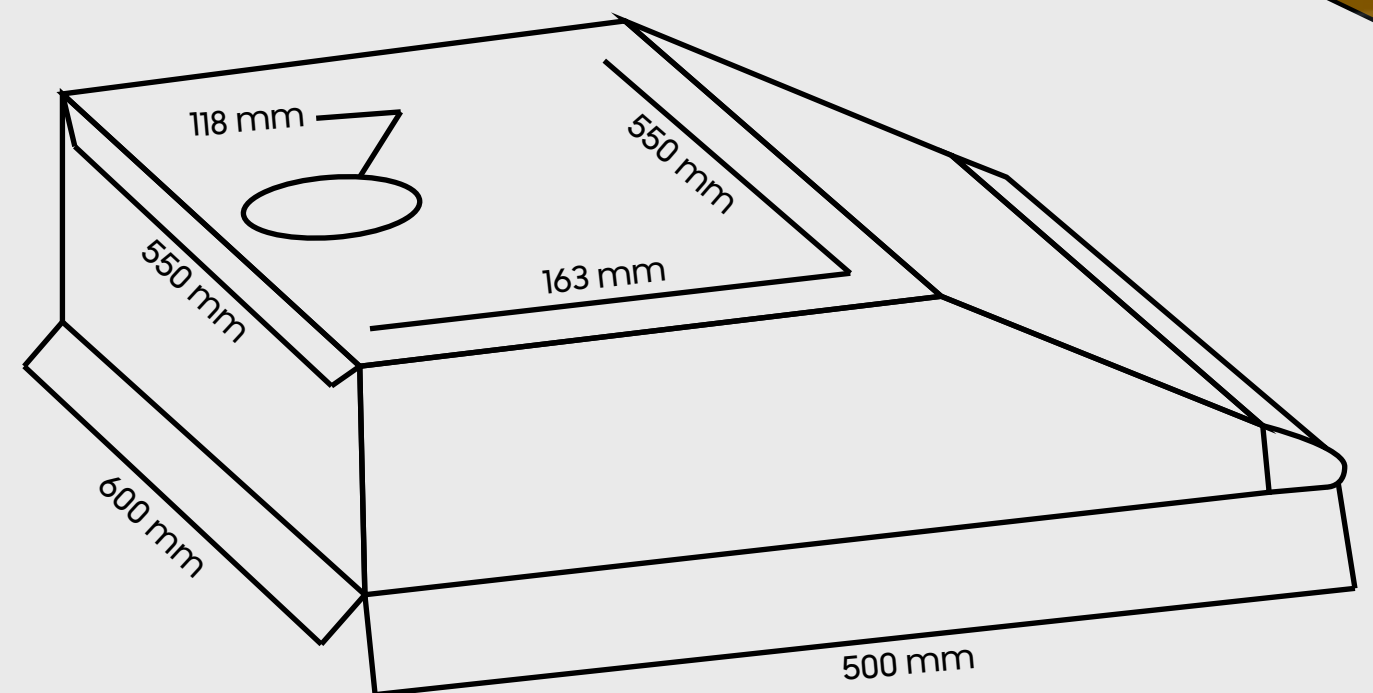

## Dimensions



## Characteristics

- Voltage: 220-240V
- Frequency: 50 Hz
- Current: 0,8 (A)
- Power: 1x95 W
- Flow rate: 280 m<sup>3</sup>/h
- Lighting: 1x2 W
- Motor insulation class: H
- Thermal protection: 120
- Number of motors: 1
- Insulation class: CLASS 1